



US 20100078629A1

(19) **United States**

(12) **Patent Application Publication**
YOKOYAMA et al.

(10) **Pub. No.: US 2010/0078629 A1**

(43) **Pub. Date: Apr. 1, 2010**

(54) **ORGANIC EL DISPLAY DEVICE**

Publication Classification

(75) Inventors: **Shuhei YOKOYAMA,**
Ishikawa-gun (JP); **Masuyuki**
Oota, Hakusan-shi (JP)

(51) **Int. Cl.**
H01L 51/52 (2006.01)
(52) **U.S. Cl.** **257/40; 257/89; 257/E51.022**

Correspondence Address:
OBLON, SPIVAK, MCCLELLAND MAIER &
NEUSTADT, L.L.P.
1940 DUKE STREET
ALEXANDRIA, VA 22314 (US)

(57) **ABSTRACT**

An organic EL display device includes a pixel electrode which is disposed in each of first to third organic EL elements, a first light emission layer which includes a first dopant material having a first absorbance peak, the first light emission layer extending over the first to third organic EL elements and being disposed above the pixel electrode, a second light emission layer which includes a second dopant material having a second absorbance peak and is disposed above the first light emission layer, a third light emission layer which is disposed above the second light emission layer, a counter-electrode which is disposed above the third light emission layer, and a hole transport layer which is formed of a material having an absorbance bottom on a shorter wavelength side than the first absorbance peak and the second absorbance peak in absorbance spectrum characteristics of the hole transport layer.

(73) Assignee: **Toshiba Mobile Display Co., Ltd.,**
Tokyo (JP)

(21) Appl. No.: **12/535,977**

(22) Filed: **Aug. 5, 2009**

(30) **Foreign Application Priority Data**

Sep. 26, 2008 (JP) 2008-248482

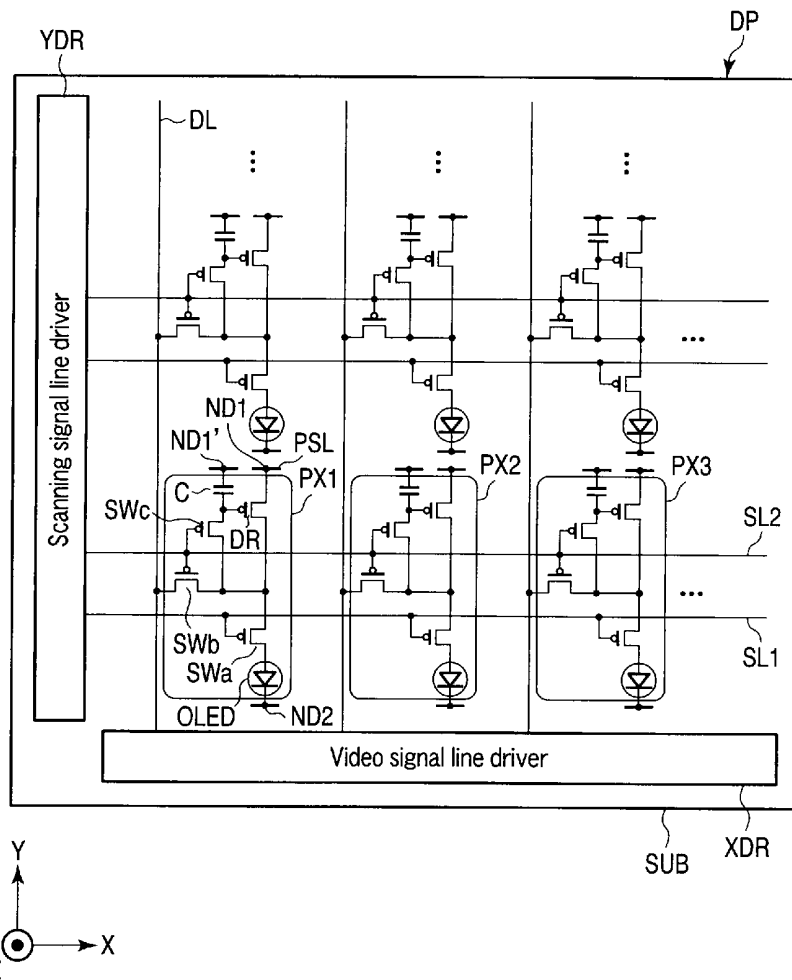

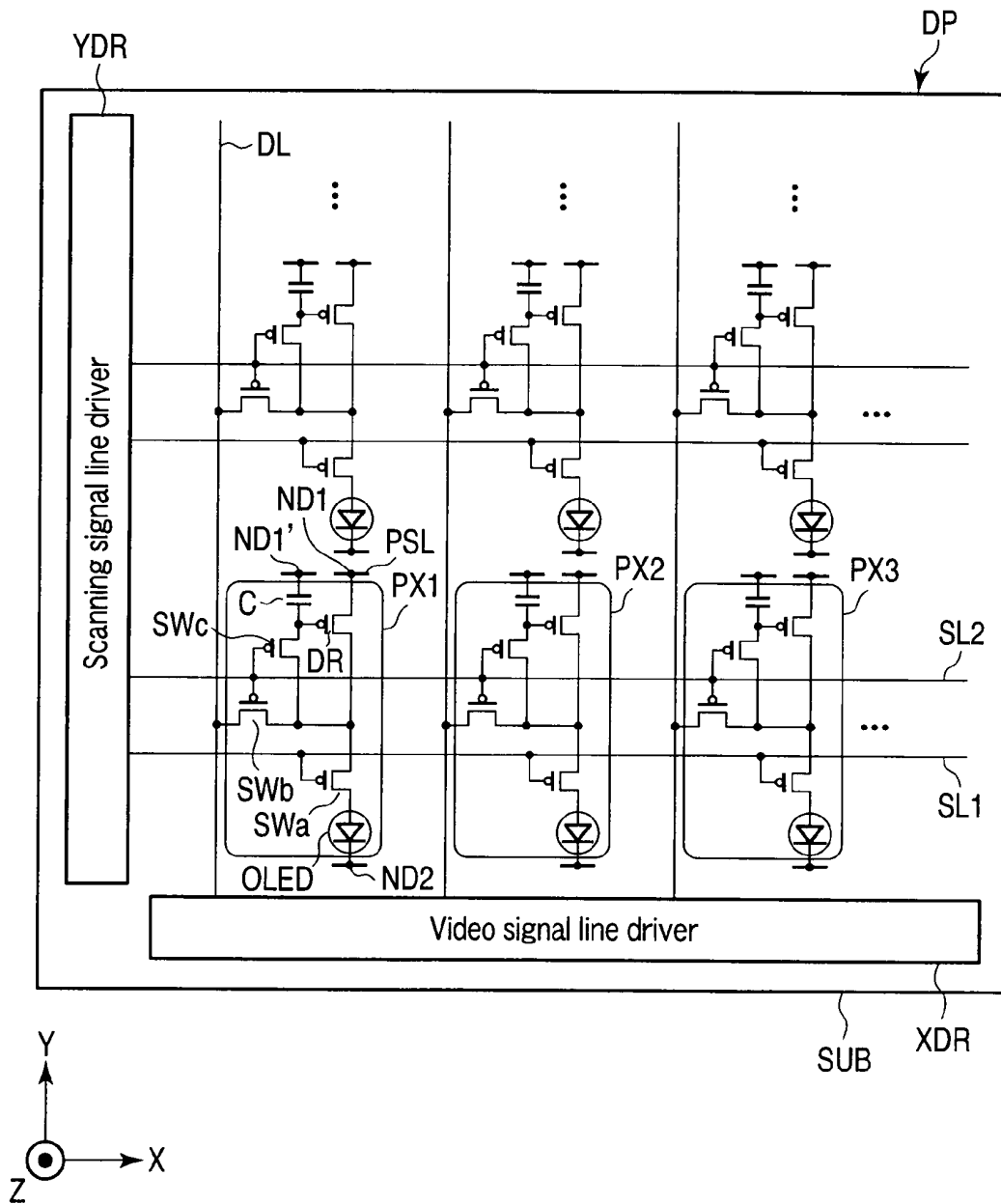

FIG. 1

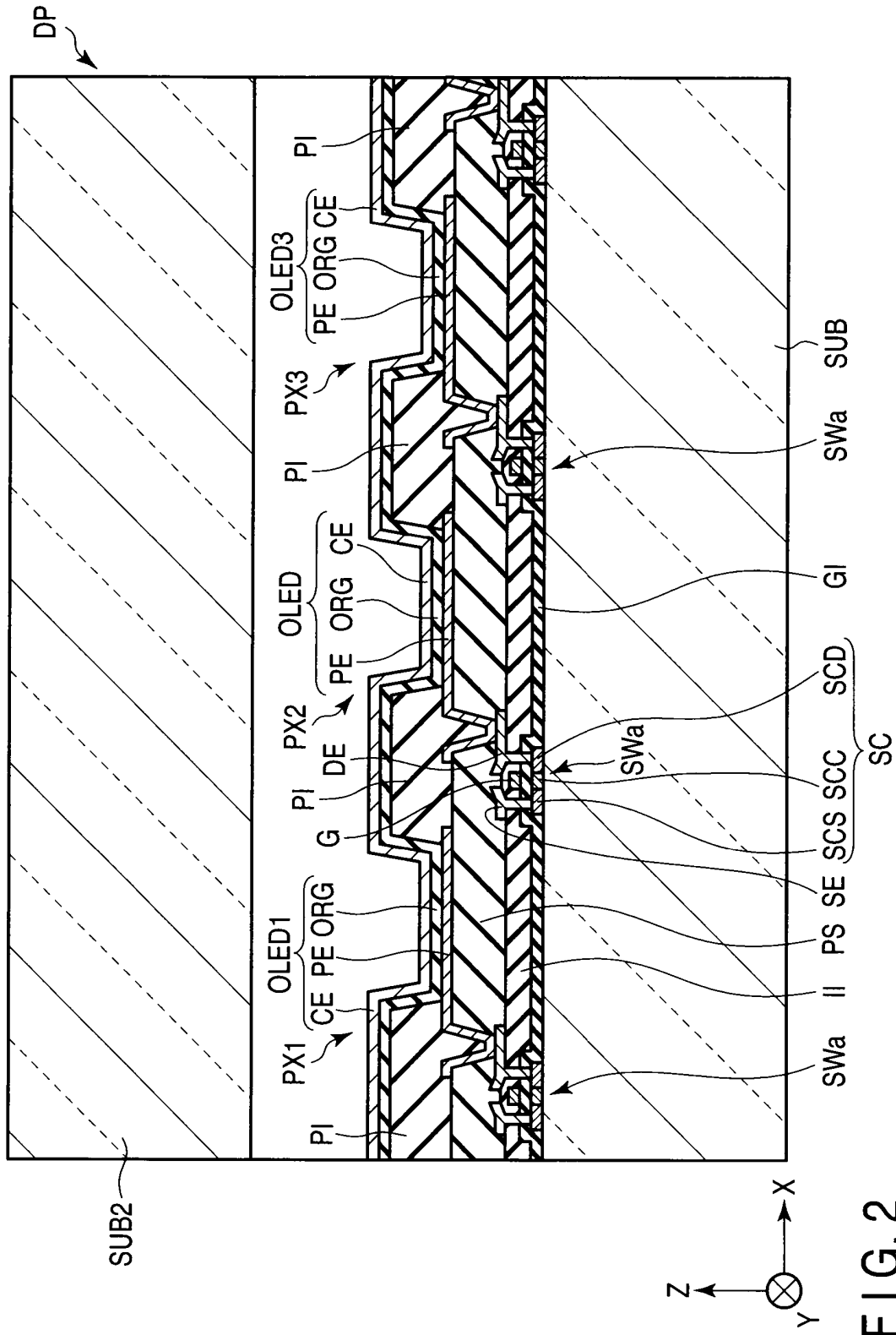

FIG. 2

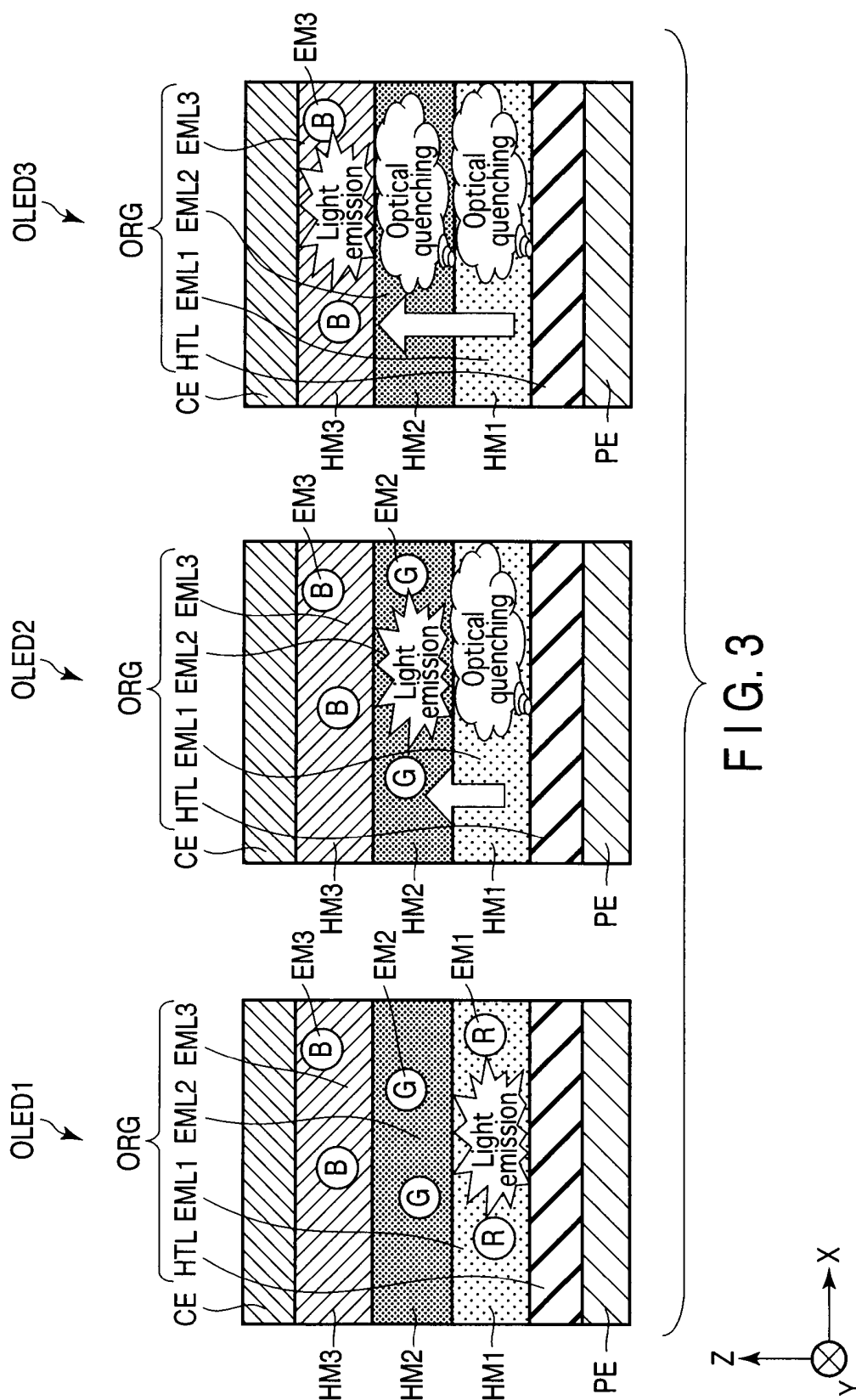

FIG. 3

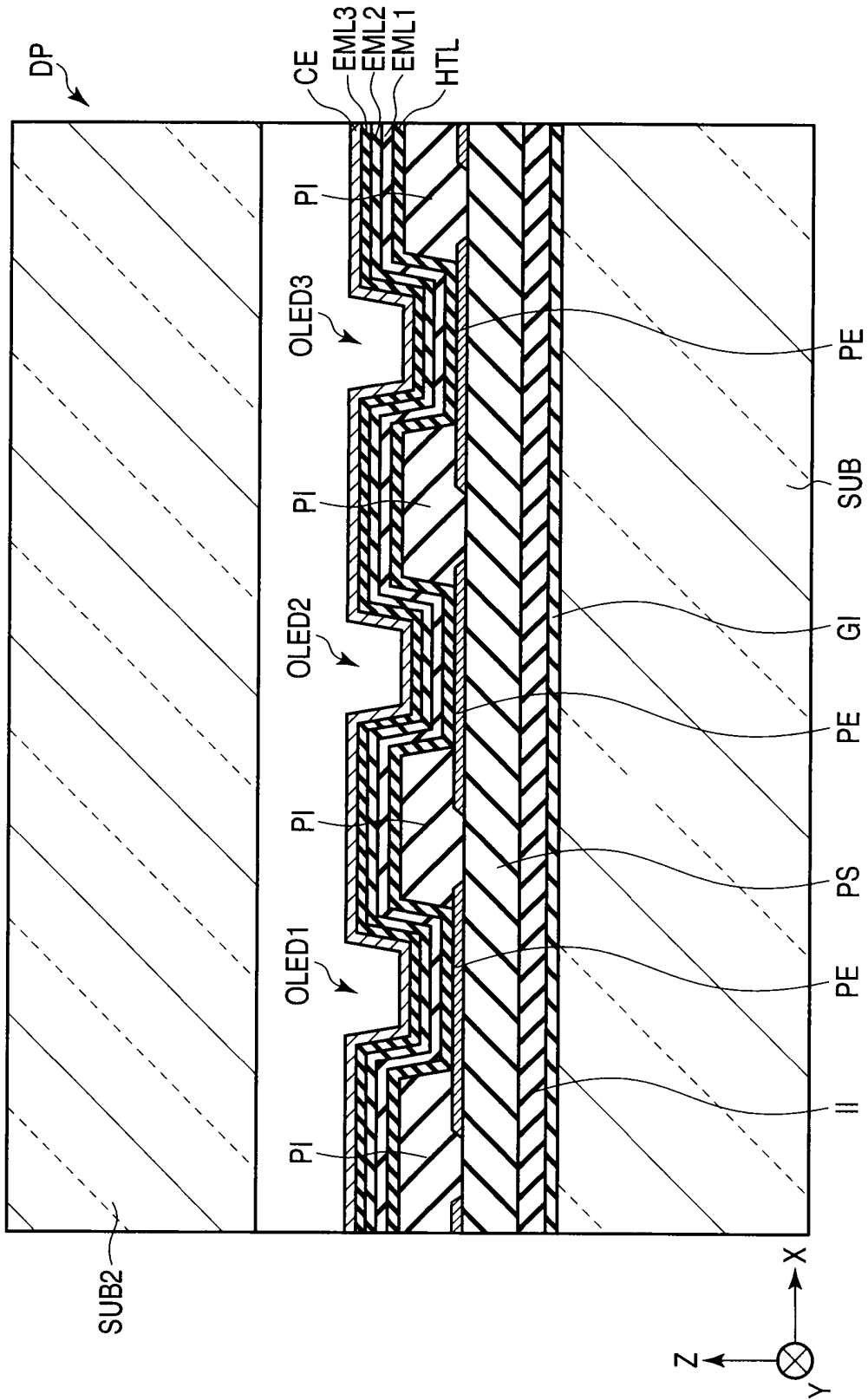

FIG. 4

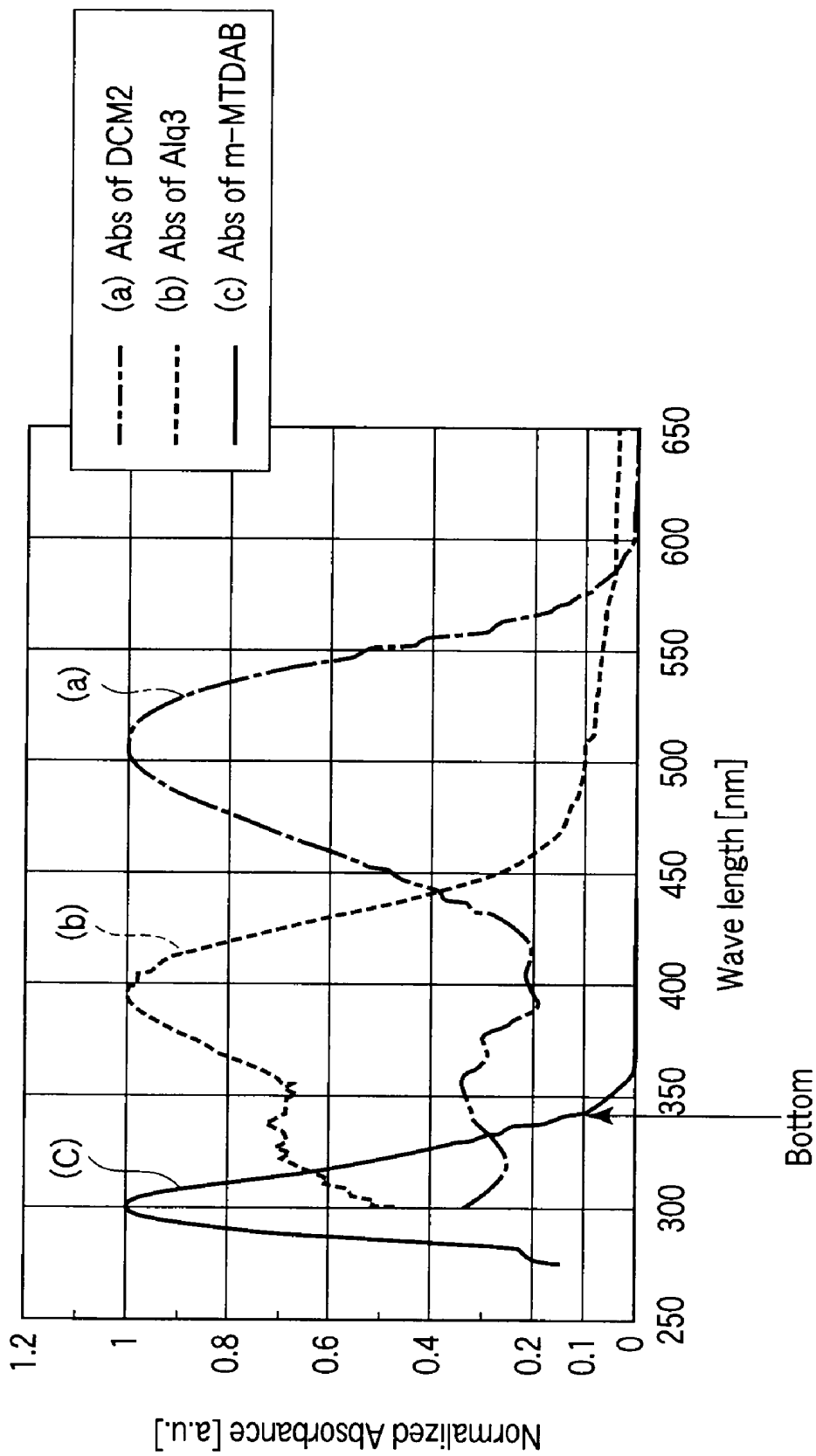

FIG. 5

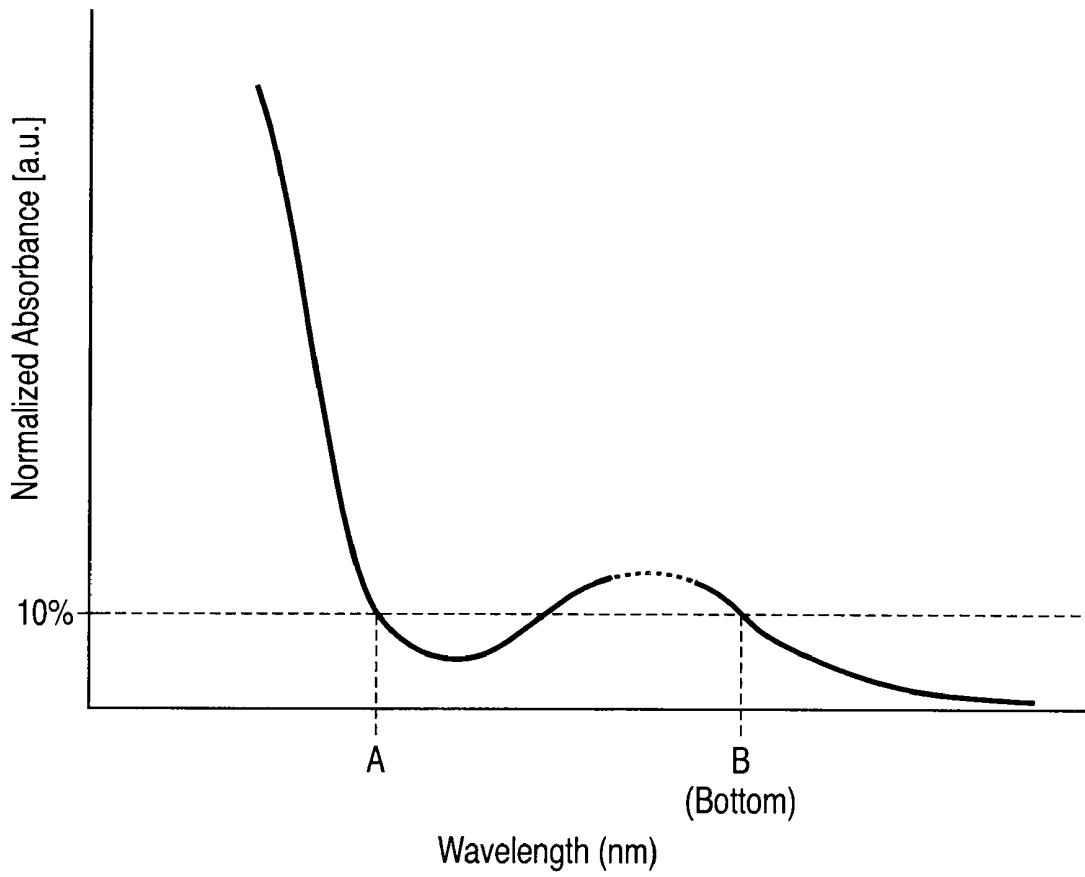

FIG. 6

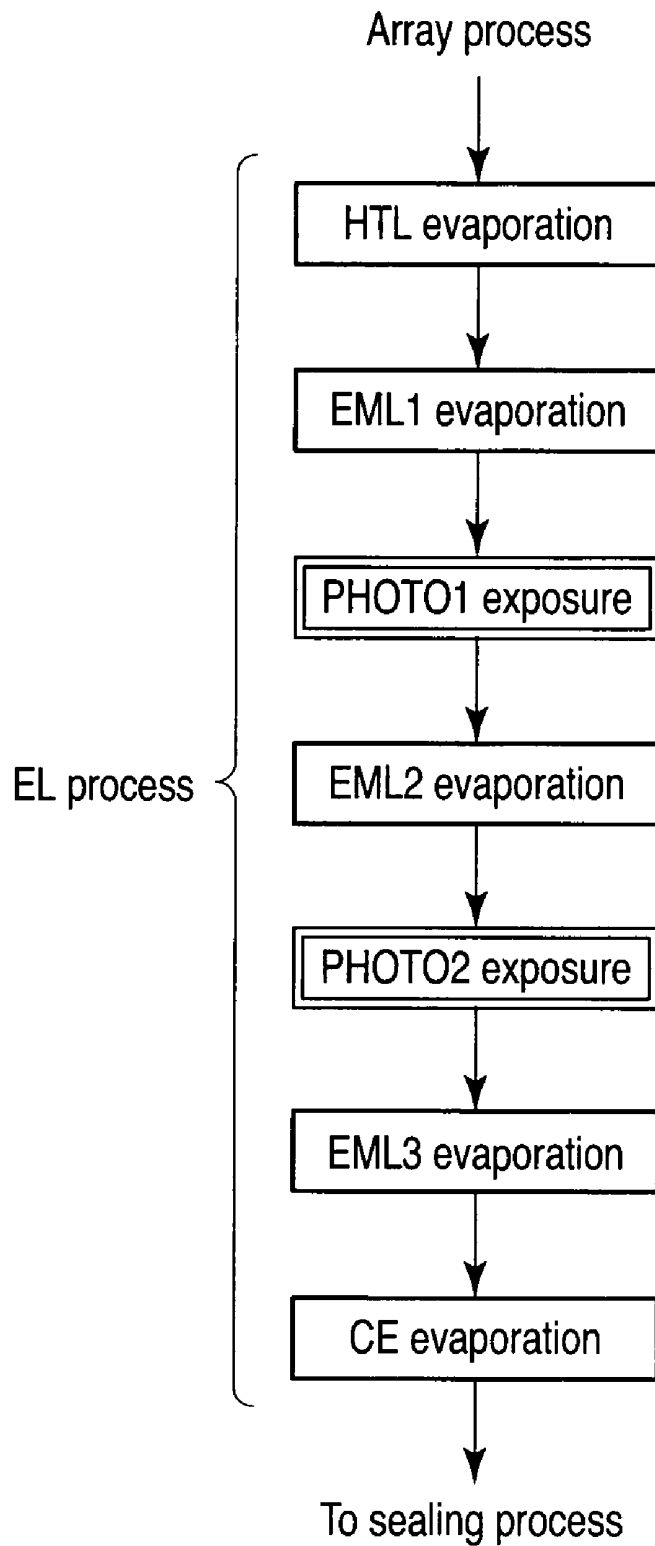

FIG. 7

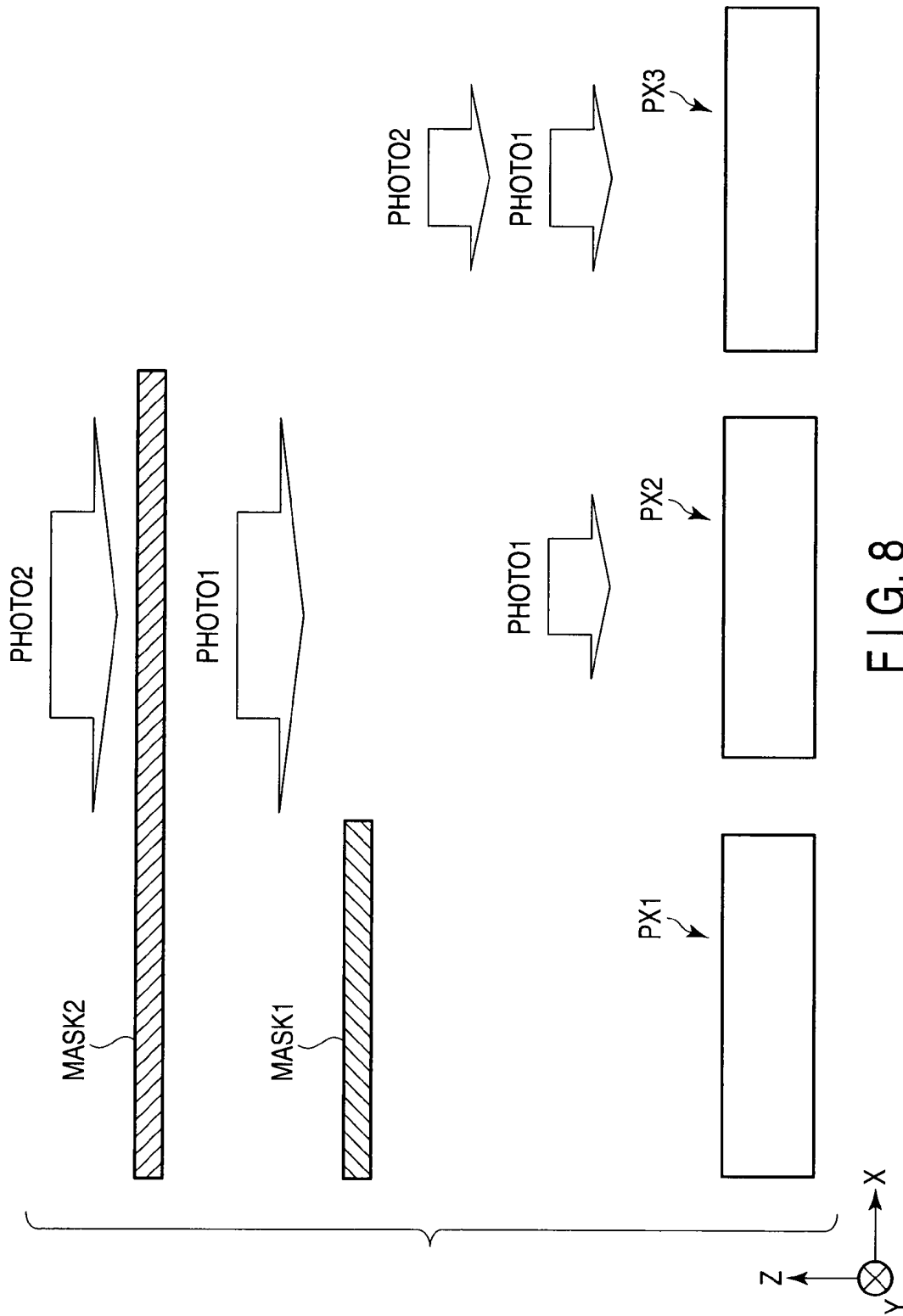

FIG. 8

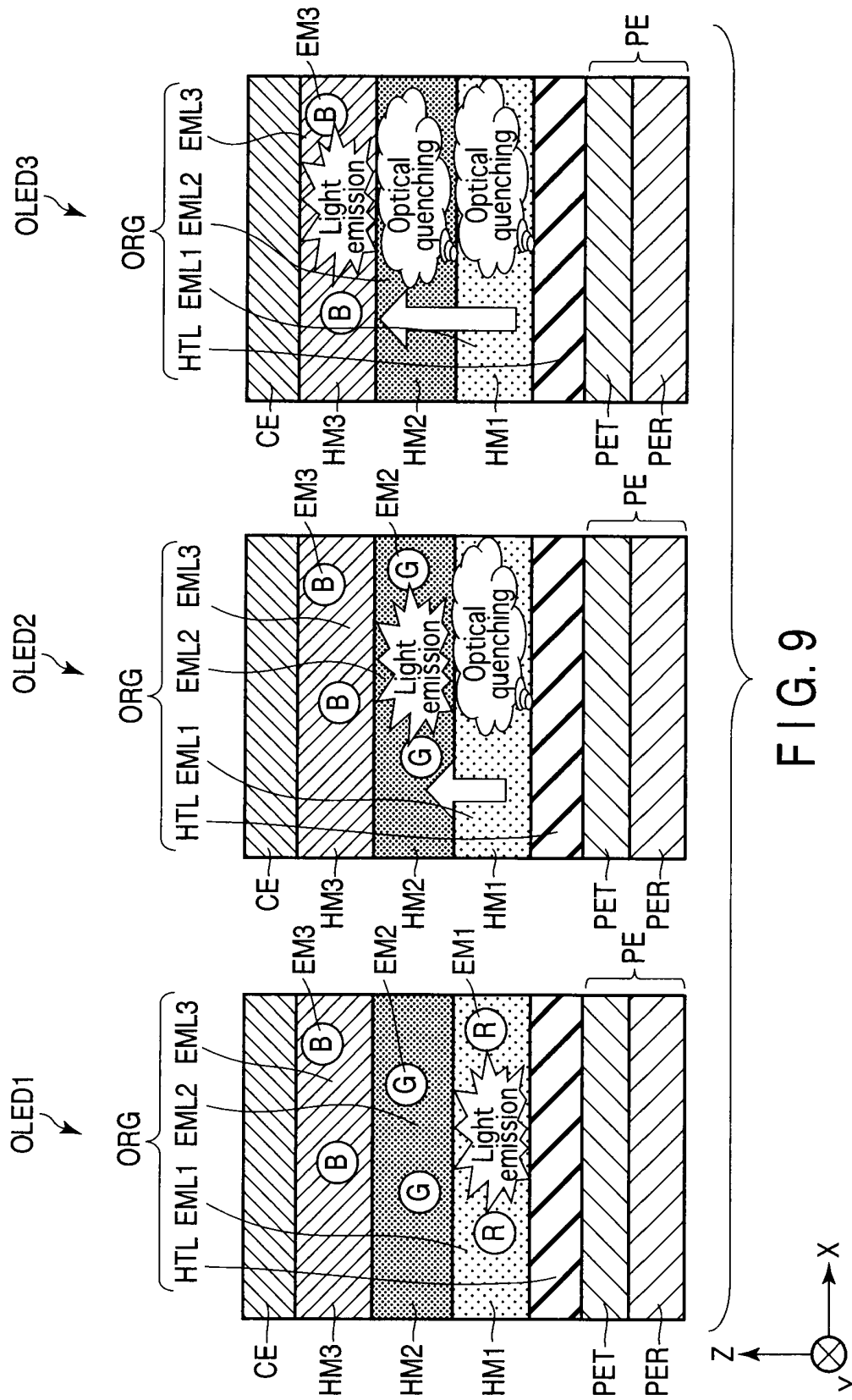

FIG. 9

ORGANIC EL DISPLAY DEVICE**CROSS-REFERENCE TO RELATED APPLICATIONS**

[0001] This application is based upon and claims the benefit of priority from prior Japanese Patent Application No. 2008-248482, filed Sep. 26, 2008, the entire contents of which are incorporated herein by reference.

BACKGROUND OF THE INVENTION

[0002] 1. Field of the Invention

[0003] The present invention relates to an organic electroluminescence (EL) display device.

[0004] 2. Description of the Related Art

[0005] In recent years, display devices using organic electroluminescence (EL) elements have vigorously been developed, by virtue of their features of self-emission, a high response speed, a wide viewing angle, a high contrast, small thickness and light weight.

[0006] In the organic EL element, holes are injected from a hole injection electrode (anode), electrons are injected from an electron injection electrode (cathode), and the holes and electrons are recombined in a light emitting layer, thereby producing light. In order to obtain full-color display, it is necessary to form pixels which emit red (R) light, green (G) light and blue (B) light, respectively. It is necessary to selectively apply light-emitting materials, which emit lights with different light emission spectra, such as red, green and blue, to light-emitting layers of organic EL elements which constitute the red, green and blue pixels. As a method for selectively applying such light-emitting materials, there is known a vacuum evaporation method. In the case of forming films of low-molecular-weight organic EL materials by such a vacuum evaporation method, there is a method in which mask evaporation is performed independently for respective color pixels by using a metallic fine mask having openings in association with the respective color pixels (see, e.g. Jpn. Pat. Appln. KOKAI Publication No. 2003-157973).

[0007] In the mask evaporation method using the metallic fine mask, however, pixels become very fine in the case where a high fineness (resolution) is required for the display device. As a result, a so-called color mixture defect, by which light-emitting materials of respective colors are mixed, occurs frequently, and full-color display with high fineness is difficult realize.

BRIEF SUMMARY OF THE INVENTION

[0008] According to an aspect of the present invention, there is provided an organic EL display device comprising: an insulative substrate; a pixel electrode which is disposed above the substrate and is disposed in each of first to third organic EL elements having different emission light colors; a first light emission layer which includes a first dopant material having a first absorbance peak in absorbance spectrum characteristics of the first dopant material, the first light emission layer extending over the first to third organic EL elements and being disposed above the pixel electrode; a second light emission layer which includes a second dopant material having a second absorbance peak in absorbance spectrum characteristics of the second dopant material, the second light emission layer extending over the first to third organic EL elements and being disposed above the first light emission layer; a third light emission layer which includes a third dopant material,

the third light emission layer extending over the first to third organic EL elements and being disposed above the second light emission layer; a counter-electrode which extends over the first to third organic EL elements and is disposed above the third light emission layer; and a hole transport layer which is formed of a material having an absorbance bottom on a shorter wavelength side than the first absorbance peak of the first dopant material and the second absorbance peak of the second dopant material in absorbance spectrum characteristics of the hole transport layer, the hole transport layer extending over the first to third organic EL elements and being disposed between the pixel electrode and the first light emission layer.

[0009] According to another aspect of the present invention, there is provided an organic EL display device comprising: an insulative substrate; a pixel electrode which is disposed above the substrate and is disposed in each of first to third organic EL elements having different emission light colors; a first light emission layer which includes a first dopant material having a first absorbance peak in absorbance spectrum characteristics of the first dopant material, the first light emission layer extending over the first to third organic EL elements and being disposed above the pixel electrode; a second light emission layer which includes a second dopant material having a second absorbance peak in absorbance spectrum characteristics of the second dopant material, the second light emission layer extending over the first to third organic EL elements and being disposed above the first light emission layer; a third light emission layer which includes a third dopant material, the third light emission layer extending over the first to third organic EL elements and being disposed above the second light emission layer; a counter-electrode which extends over the first to third organic EL elements and is disposed above the third light emission layer; and a hole transport layer which has an absorbance bottom, at which a normalized absorbance is 10% or less, on a shorter wavelength side than the first absorbance peak of the first dopant material and the second absorbance peak of the second dopant material in normalized absorbance spectrum characteristics of the hole transport layer, the hole transport layer extending over the first to third organic EL elements and being disposed between the pixel electrode and the first light emission layer.

BRIEF DESCRIPTION OF THE SEVERAL VIEWS OF THE DRAWING

[0010] The accompanying drawings, which are incorporated in and constitute a part of the specification, illustrate embodiments of the invention, and together with the general description given above and the detailed description of the embodiments given below, serve to explain the principles of the invention.

[0011] FIG. 1 schematically shows the structure of an organic EL display device according to an embodiment of the present invention;

[0012] FIG. 2 is a cross-sectional view which schematically shows the structure of a display panel, which is adoptable in the organic EL display device shown in FIG. 1;

[0013] FIG. 3 shows one principle for controlling the emission light colors of first to third organic EL elements;

[0014] FIG. 4 is a cross-sectional view which schematically shows the structure of the first to third organic EL elements shown in FIG. 3;

[0015] FIG. 5 is a graph showing light absorbance spectrum characteristics of a first dopant material, a second dopant material and a hole transport layer, which are adopted in the organic EL display device shown in FIG. 2;

[0016] FIG. 6 is a graph for explaining a light absorbance bottom in normalized light absorbance spectrum characteristics;

[0017] FIG. 7 is a flow chart for describing a manufacturing method for manufacturing the first to third organic EL elements shown in FIG. 3;

[0018] FIG. 8 is a view for explaining exposure steps which are indicated by "PHOTO1 EXPOSURE" and "PHOTO2 EXPOSURE" in FIG. 7; and

[0019] FIG. 9 schematically shows another structure example of the first to third organic EL elements.

DETAILED DESCRIPTION OF THE INVENTION

[0020] An embodiment of the present invention will now be described in detail with reference to the accompanying drawings. In the drawings, structural elements having the same or similar functions are denoted by like reference numerals, and an overlapping description is omitted.

[0021] In the present embodiment, as an example of the organic EL display device, a description is given of an organic EL display device of a top emission type, which adopts an active matrix driving method.

[0022] As shown in FIG. 1, this display device includes a display panel DP. The display panel DP includes an insulative substrate SUB such as a glass substrate.

[0023] Pixels PX1 to PX3 are arranged in an X direction in the named order, and constitute a triplet (unit pixel) which is a minimum unit of a display pixel. In a display region, such triplets are arranged in the X direction and Y direction. Specifically, in the display region, a pixel string in which pixels PX1 are arranged in the Y direction, a pixel string in which pixels PX2 are arranged in the Y direction and a pixel string in which pixels PX3 are arranged in the Y direction are arranged in the X direction in the named order, and these three pixel strings are repeatedly arranged in the X direction.

[0024] Each of the pixels PX1 to PX3 includes a driving transistor DR, switching transistors SWa to SWc, an organic EL element OLED, and a capacitor C. In this example, the driving transistor DR and switching transistors SWa to SWc are p-channel thin-film transistors.

[0025] Scanning signal lines SL1 and SL2 extend in the X direction. Video signal lines DL extend in the Y direction. The driving transistor DR, switching transistor SWa and organic EL element OLED are connected in series in the named order between a first power supply terminal ND1 and a second power supply terminal ND2. In this example, the power supply terminal ND1 is a high-potential power supply terminal, and the power supply terminal ND2 is a low-potential power supply terminal. The power supply terminal ND1 is connected to a power supply line PSL.

[0026] The gate electrode of the switching transistor SWa is connected to the scanning signal line SL1. The switching transistor SWb is connected between the video signal line DL and the drain electrode of the driving transistor DR, and the gate electrode of the switching transistor SWb is connected to the scanning signal line SL2. The switching transistor SWc is connected between the drain electrode and gate electrode of the driving transistor DR, and the gate electrode of the switching transistor SWc is connected to the scanning signal line SL2. The capacitor C is connected between the gate electrode

of the driving transistor DR and a constant potential terminal ND1'. In this example, the constant potential terminal ND1' is connected to the power supply terminal ND1.

[0027] The video signal line driver XDR and scanning signal line driver YDR are disposed, for example, on the substrate SUB. Specifically, the video signal line driver XDR and scanning signal line driver YDR are implemented by chip on glass (COG). The video signal line driver XDR and scanning signal line driver YDR may be implemented by tape carrier package (TCP), instead of COG. Alternatively, the video signal line driver XDR and scanning signal line driver YDR may be directly formed on the substrate SUB.

[0028] The video signal lines DL are connected to the video signal line driver XDR. The video signal line driver XDR outputs current signals as video signals to the video signal lines DL.

[0029] The scanning signal lines SL1 and SL2 are connected to the scanning signal line driver YDR. The scanning signal line driver YDR outputs voltage signals as first and second scanning signals to the scanning signal lines SL1 and SL2.

[0030] When an image is to be displayed on this organic EL display device, for example, the scanning signal lines SL2 are successively scanned. Specifically, the pixels PX1 to PX3 are selected on a row-by-row basis. In a selection period in which a certain row is selected, a write operation is executed in the pixels PX1 to PX3 included in this row. In a non-selection period in which this row is not selected, a display operation is executed in the pixels PX1 to PX3 included in this row.

[0031] In the selection period in which the pixels PX1 to PX3 of a certain row are selected, the scanning signal line driver YDR outputs, as voltage signals, scanning signals for opening (rendering non-conductive) the switching transistors SWa to the scanning signal line SL1 to which the pixels PX1 to PX3 are connected. Then, the scanning signal line driver YDR outputs, as voltage signals, scanning signals for closing (rendering conductive) the switching transistors SWb and SWc to the scanning signal line SL2 to which the pixels PX1 to PX3 are connected. In this state, the video signal line driver XDR outputs, as current signals (write current) I_{sig} , video signals to the video signal lines DL, and sets a gate-source voltage V_{gs} of the driving transistor DR at a magnitude corresponding to the video signal I_{sig} .

[0032] Subsequently, the scanning signal line driver YDR outputs, as voltage signals, scanning signals for opening the switching transistors SWb and SWc to the scanning signal line SL2 to which the pixels PX1 to PX3 are connected, and then outputs, as voltage signals, scanning signals for closing the switching transistors SWa to the scanning signal line SL1 to which the pixels PX1 to PX3 are connected. Thus, the selection period ends.

[0033] In the non-selection period following the selection period, the switching transistors SWa are kept closed, and the switching transistors SWb and SWc are kept opened. In the non-selection period, a driving current I_{drv} which corresponds in magnitude to the gate-source voltage V_{gs} of the driving transistor DR, flows in the organic EL element OLED. The organic EL element OLED emits light with a luminance corresponding to the magnitude of the driving current I_{drv} . In this case, $I_{drv} \approx I_{sig}$, and emission light corresponding to the current signal (write current) I_{sig} can be obtained in each pixel.

[0034] In the above-described example, the structure in which the current signal is written as the video signal is

adopted in the pixel circuit for driving the organic EL element OLED. Alternatively, a structure in which a voltage signal is written as the video signal may be adopted in the pixel circuit. The invention is not restricted to the above-described example. In the present embodiment, use is made of p-channel thin-film transistors. Alternatively, n-channel thin-film transistors may be used, with the spirit of the invention being unchanged. The pixel circuit is not limited to the above-described example, and various modes may be applicable to the pixel circuit.

[0035] FIG. 2 schematically shows the cross-sectional structure of the display panel DP which includes the switching transistor SWa and the organic EL element OLED.

[0036] As shown in FIG. 2, a semiconductor layer SC of the switching transistor SWa is disposed on the substrate SUB. The semiconductor layer SC is formed of, e.g. polysilicon. In the semiconductor layer SC, a source region SCS and a drain region SCD are formed, with a channel region SCC being interposed.

[0037] The semiconductor layer SC is coated with a gate insulation film GI. The gate electrode G of the switching transistor SWa is disposed on the gate insulation film GI immediately above the channel region SCC. In this example, the switching transistor SWa is a top-gate-type p-channel thin-film transistor.

[0038] The gate insulation film GI and the gate electrode G are coated with an interlayer insulation film II. A source electrode SE and a drain electrode DE of the switching transistor SWa are disposed on the interlayer insulation film II. The source electrode SE is connected to the source region SCS of the semiconductor layer SC. The drain electrode DE is connected to the drain region SCD of the semiconductor layer SC. The source electrode SE and drain electrode DE are coated with a passivation film PS. The passivation film PS is also disposed on the interlayer insulation film II.

[0039] Pixel electrodes PE are disposed on the passivation film PS in association with the pixels PX1 to PX3. Each pixel electrode PE is connected to the drain electrode DE of the switching transistor SWa. In this example, the pixel electrode PE corresponds to an anode.

[0040] A partition wall PI is formed on the passivation film PS. The partition wall PI is disposed in a lattice shape in a manner to surround the entire periphery of the pixel electrode PE. The partition wall PI may be disposed in a stripe shape extending in the Y direction between the pixel electrodes PE.

[0041] An organic layer ORG is disposed on each pixel electrode PE. The organic layer ORG includes at least one continuous film which extends over the display region including all pixels PX1 to PX3. Specifically, the organic layer ORG covers the pixel electrodes PE and partition wall PI. The details will be described later.

[0042] The organic layer ORG is coated with a counter-electrode CE. In this example, the counter-electrode CE corresponds to a cathode. The counter-electrode CE is a continuous film which extends over the display region including all pixels PX1 to PX3. In short, the counter-electrode CE is a common electrode which is shared by the pixels PX1 to PX3.

[0043] The pixel electrodes PE, organic layer ORG and counter-electrode CE constitute first to third organic EL elements OLED1 to OLED3 which are disposed in association with the pixels PX1 to PX3. Specifically, the pixel PX1 includes the first organic EL element OLED1, the pixel PX2 includes the second organic EL element OLED2, and the pixel PX3 includes the third organic EL element OLED3.

Although FIG. 2 shows one first organic EL element OLED1 of the pixel PX1, one second organic EL element OLED2 of the pixel PX2 and one third organic EL element OLED3 of the pixel PX3, these organic EL elements OLED1, OLED2 and OLED3 are repeatedly disposed in the X direction. Specifically, another first organic EL element OLED1 is disposed adjacent to the third organic EL element OLED3 that is shown on the right side part of FIG. 2. Similarly, another third organic EL element OLED3 is disposed adjacent to the first organic EL element OLED1 that is shown on the left side part of FIG. 2.

[0044] The partition wall PI is disposed between, and divides, the first organic EL element OLED1 and second organic EL element OLED2. In addition, the partition wall PI is disposed between, and divides, the second organic EL element OLED2 and third organic EL element OLED3. Further, the partition wall PI is disposed between, and divides, the third organic EL element OLED3 and first organic EL element OLED1.

[0045] The sealing of the first to third organic EL elements OLED1 to OLED3 may be effected by bonding a sealing substrate SUB2, to which a desiccant (not shown) is attached, by means of a sealant which is applied to the periphery of the display region. Alternatively, the sealing of the first to third organic EL elements OLED1 to OLED3 may be effected by bonding the sealing substrate SUB2 by means of frit glass (frit sealing), or by filling an organic resin layer between the sealing substrate SUB2 and the organic EL element OLED (solid sealing). In the case of the frit sealing, the desiccant may be dispensed with. In the case of the solid sealing, an insulation film of an inorganic material, in addition to the organic resin layer, may be interposed between the sealing substrate SUB2 and the counter-electrode CE. The sealing substrate SUB2 is formed of, e.g. a glass substrate.

[0046] In the present embodiment, the first to third organic EL elements OLED1 to OLED3 are configured to have different emission light colors. In this example, the emission light color of the first organic EL element OLED1 is red, the emission light color of the second organic EL element OLED2 is green, and the emission light color of the third organic EL element OLED3 is blue.

[0047] In general, the color of light in the range of wavelengths of 400 nm to 435 nm is defined as purple; the color of light in the range of wavelengths of 435 nm to 480 nm is defined as blue; the color of light in the range of wavelengths of 480 nm to 490 nm is defined as greenish blue; the color of light in the range of wavelengths of 490 nm to 500 nm is defined as bluish green; the color of light in the range of wavelengths of 500 nm to 560 nm is defined as green; the color of light in the range of wavelengths of 560 nm to 580 nm is defined as yellowish green; the color of light in the range of wavelengths of 580 nm to 595 nm is defined as yellow; the color of light in the range of wavelengths of 595 nm to 610 nm is defined as orange; the color of light in the range of wavelengths of 610 nm to 750 nm is defined as red; and the color of light in the range of wavelengths of 750 nm to 800 nm is defined as purplish red.

[0048] In this example, the range of a major wavelength between 595 nm and 800 nm is defined as a first wavelength range, and the color in the first wavelength range is set to be red. The range of a major wavelength, which is greater than 490 nm and less than 595 nm, is defined as a second wavelength range, and the color in the second wavelength range is set to be green. The range of a major wavelength between 400

nm to 490 nm is defined as a third wavelength range, and the color in the third wavelength range is set to be blue.

[0049] FIG. 3 schematically shows the structure of each of the first to third organic EL elements OLED1 to OLED3. Each of the first organic EL element OLED1, the second organic EL element OLED2 and the third organic EL element OLED3 includes a pixel electrode PE, a counter-electrode CE that is opposed to the pixel electrode PE, and an organic layer ORG that is interposed between the pixel electrode PE and counter-electrode CE.

[0050] The first to third organic EL elements OLED1 to OLED3 are structured as described below.

[0051] Specifically, the organic layer ORG is disposed on the pixel electrode PE. The organic layer ORG includes a hole transport layer HTL which is disposed on the pixel electrode PE, a red light emission layer EML1 which is a first light emission layer disposed on the hole transport layer HTL, a green light emission layer EML2 which is a second light emission layer disposed on the red light emission layer EML1, and a blue light emission layer EML3 which is a third light emission layer disposed on the green light emission layer EML2. The counter-electrode CE is disposed on the organic layer ORG.

[0052] The hole transport layer HTL is formed by using, e.g. 1,3,5-Tris(3-methyldiphenylamino)-benzene (abbreviation: m-MTDAB). The film thickness of the hole transport layer HTL is, e.g. 30 nm.

[0053] The red light emission layer EML1 is formed of a mixture of a first host material HM1 and a first dopant material EM1 whose emission light color is red. The first dopant material EM1 is a red light-emitting material which is formed of a luminescent organic compound or composition having a central light emission wavelength in red wavelengths of the first wavelength range. The red light emission layer EML1 is formed, for example, by using 9,9-bis(9-phenyl-9H-carbazole) fluorine (abbreviation: FL-2CBP) as the first host material HM1, and 4-(dicyanomethylene)-2-methyl-6-(julolidin-4-yl-vinyl)-4H-pyran (DCM2) as the first dopant material EM1. The film thickness of the red light emission layer EML1 is, e.g. 30 nm.

[0054] The green light emission layer EML2 is formed of a mixture of a second host material HM2 and a second dopant material EM2 whose emission light color is green. The second dopant material EM2 is a green light-emitting material which is formed of a luminescent organic compound or composition having a central light emission wavelength in green wavelengths of the second wavelength range. The green light emission layer EML2 is formed, for example, by using FL-2CBP as the second host material HM2, and tris(8-hydroxyquinolato)aluminum (abbreviation: Alq₃) as the second dopant material EM2. The film thickness of the green light emission layer EML2 is, e.g. 30 nm.

[0055] The blue light emission layer EML3 is formed of a mixture of a third host material HM3 and a third dopant material EM3 whose emission light color is blue. The third dopant material EM3 is a blue light-emitting material which is formed of a luminescent organic compound or composition having a central light emission wavelength in blue wavelengths of the third wavelength range. The blue light emission layer EML3 is formed, for example, by using 4,4'-bis(2,2'-diphenyl-ethen-1-yl)-diphenyl (BPVBI) as the third host material, and perylene as the third dopant material EM3. The film thickness of the blue light emission layer EML3 is, e.g. 30 nm.

[0056] As the first host material HM1, second host material HM2 and third host material HM3, use may be made of 1,3,5-tris(carbazole-9-yl) benzene (abbreviation: TCP), aside from the above-described examples. Other materials may also be used.

[0057] Materials, other than the above-described examples, may be used as the first dopant material EM1, second dopant material EM2 and third dopant material EM3. At least one of the first dopant material EM1, second dopant material EM2 and third dopant material EM3 may be a phosphorescent material.

[0058] The characteristics which the material of the hole transport layer HTL is required to have are such absorbance spectrum characteristics as to have an absorbance bottom on a shorter wavelength side than a first absorbance peak in absorbance spectrum characteristics of the first dopant material EM1 and a second absorbance peak in absorbance spectrum characteristics of the second dopant material EM2.

[0059] A description is given of the principle for controlling the emission light colors in the first to third organic EL elements OLED1 to OLED3.

[0060] The band gap of the first dopant material EM1 is smaller than the band gap of each of the second dopant material EM2 and third dopant material EM3. The band gap of the second dopant material EM2 is smaller than the band gap of the third dopant material EM3. The band gap corresponds to an energy difference between a lowest unoccupied molecular orbital (LUMO) and a highest occupied molecular orbital (HOMO).

[0061] In the first organic EL element OLED1, since the band gap of the first dopant material EM1 that is included in the red light emission layer EML1 is smallest, no energy transition occurs to other layers. Therefore, the first organic EL element OLED1 emits red light, and neither the green light emission layer EML2 nor blue light emission layer EML3 emits light.

[0062] In the second organic EL element OLED2, the first dopant material EM1 of the red light emission layer EML1 is in an optical quenching state. The optical quenching state refers to a state in which the dopant material absorbs ultraviolet and thus decomposition, polymerization or a change in molecular structure occurs in the dopant material, and, as a result, light emission does not occur or light emission hardly occurs. In the red light emission layer EML1 of the second organic EL element OLED2, the first dopant material EM1 emits no light. Even if the first dopant material EM1 is in the optical quenching state, the band gap in the red light emission layer EML1 is substantially equal to or less than the band gap prior to the optical quenching.

[0063] At this time, in the red light emission layer EML1 of the second organic EL element OLED2, the hole injectability or hole transportability of the red light emission layer EML1 increases by the ultraviolet irradiation for the optical quenching of the first dopant material EM1, and the hole mobility becomes higher than in the state prior to the ultraviolet radiation. Hence, in the second organic EL element OLED2, the balance between electrons and holes varies, and the light emission position shifts to the green light emission layer EML2. Therefore, the second organic EL element OLED2 emits green light, and the blue light emission layer EML3 emits no light.

[0064] In the third organic EL element OLED3, the first dopant material EM1 of the red light emission layer EML1 and the second dopant material EM2 of the green light emis-

sion layer EML2 are in the optical quenching state. In the red light emission layer EML1 of the third organic EL element OLED3, the first dopant material EM1 emits no light. In addition, in the green light emission layer EML2 of the third organic EL element OLED3, the second dopant material EM2 emits no light. Even if the first dopant material EM1 is in the optical quenching state, the band gap in the red light emission layer EML1 is substantially equal to or less than the band gap prior to the optical quenching. In addition, even if the second dopant material EM2 is in the optical quenching state, the band gap in the green light emission layer EML2 is substantially equal to or less than the band gap prior to the optical quenching.

[0065] At this time, in the red light emission layer EML1 of the third organic EL element OLED3, like the second organic EL element OLED2, the hole injectability or hole transportability increases. Similarly, in the green light emission layer EML2 of the third organic EL element OLED3, the hole injectability or hole transportability of the green light emission layer EML2 increases by the ultraviolet irradiation for the optical quenching of the second dopant material EM2, and the hole mobility becomes higher than in the state prior to the ultraviolet radiation. Hence, in the third organic EL element OLED3, the balance between electrons and holes further varies, and the light emission position shifts to the blue light emission layer EML3. Therefore, the third organic EL element OLED3 emits blue light.

[0066] FIG. 4 schematically shows the cross-sectional structure of the display panel DP including the first to third organic EL elements OLED1 to OLED3. The cross-sectional structure shown in FIG. 4 does not include the switching transistor.

[0067] As shown in FIG. 4, the gate insulation film GI, interlayer insulation film II and passivation film PS are interposed between the substrate SUB and the pixel electrode PE of each of the first to third organic EL elements OLED1 to OLED3. Each pixel electrode PE is disposed on the passivation film PS.

[0068] The hole transport layer HTL is disposed on the pixel electrode PE of each of the first to third organic EL elements OLED1 to OLED3. The hole transport layer HTL extends over the first to third organic EL elements OLED1 to OLED3. Specifically, the hole transport layer HTL is a continuous film spreading over the display region, and is disposed common to the first to third organic EL elements OLED1 to OLED3. In addition, the hole transport layer HTL is disposed on each of the partition walls PI which are disposed between the first organic EL element OLED1 and second organic EL element OLED2, between the second organic EL element OLED2 and third organic EL element OLED3, and between the third organic EL element OLED3 and first organic EL element OLED1.

[0069] The red light emission layer EML1 extends over the first to third organic EL elements OLED1 to OLED3, and is disposed on the hole transport layer HTL. Specifically, the red light emission layer EML1 is a continuous film spreading over the display region, and is disposed common to the first to third organic EL elements OLED1 to OLED3. In addition, the red light emission layer EML1 is disposed on the hole transport layer HTL above the partition walls PI which are disposed between the first organic EL element OLED1 and second organic EL element OLED2, between the second organic EL element OLED2 and third organic EL element

OLED3, and between the third organic EL element OLED3 and first organic EL element OLED1.

[0070] The green light emission layer EML2 extends over the first to third organic EL elements OLED1 to OLED3, and is disposed on the red light emission layer EML1. Specifically, the green light emission layer EML2 is a continuous film spreading over the display region, and is disposed common to the first to third organic EL elements OLED1 to OLED3. In addition, the green light emission layer EML2 is disposed on the red light emission layer EML1 above the partition walls PI which are disposed between the first organic EL element OLED1 and second organic EL element OLED2, between the second organic EL element OLED2 and third organic EL element OLED3, and between the third organic EL element OLED3 and first organic EL element OLED1.

[0071] The blue light emission layer EML3 extends over the first to third organic EL elements OLED1 to OLED3, and is disposed on the green light emission layer EML2. Specifically, the blue light emission layer EML3 is a continuous film spreading over the display region, and is disposed common to the first to third organic EL elements OLED1 to OLED3. In addition, the blue light emission layer EML3 is disposed on the green light emission layer EML2 above the partition walls PI which are disposed between the first organic EL element OLED1 and second organic EL element OLED2, between the second organic EL element OLED2 and third organic EL element OLED3, and between the third organic EL element OLED3 and first organic EL element OLED1.

[0072] The counter-electrode CE extends over the first to third organic EL elements OLED1 to OLED3, and is disposed on the blue light emission layer EML3. Specifically, the counter-electrode CE is a continuous film spreading over the display region, and is disposed common to the first to third organic EL elements OLED1 to OLED3. In addition, the counter-electrode CE is disposed on the blue light emission layer EML3 above the partition walls PI which are disposed between the first organic EL element OLED1 and second organic EL element OLED2, between the second organic EL element OLED2 and third organic EL element OLED3, and between the third organic EL element OLED3 and first organic EL element OLED1.

[0073] The first to third organic EL elements OLED1 to OLED3 are sealed by using the sealing substrate SUB2.

[0074] FIG. 5 shows normalized light absorbance spectrum characteristics of DCM2 that is the first dopant material EM1, Alq₃ that is the second dopant material EM2, and m-MTDAB that is the material of which the hole transport layer HTL is formed. The light absorbance spectrum characteristics indicate the absorbance of each material, which is calculated on the basis of the transmittance of each material at a time when reference light in a wavelength range between 275 nm to 650 nm is radiated on each material. The normalized light absorbance spectrum characteristics are calculated on the assumption that the maximum value of the absorbance in the wavelength range of 275 nm to 650 nm is 1.0, i.e. the normalized absorbance.

[0075] The first dopant material EM1 has absorbance spectrum characteristics which are indicated by (a) in FIG. 5, and has a first absorbance peak in the vicinity of the wavelength of 500 nm. The second dopant material EM2 has absorbance spectrum characteristics which are indicated by (b) in FIG. 5, and has a second absorbance peak in the vicinity of the wavelength of 400 nm.

[0076] The hole transport layer HTL has absorbance spectrum characteristics which are indicated by (c) in FIG. 5, and has a third absorbance peak in the vicinity of the wavelength of 300 nm and a substantial absorbance bottom at the wavelength of 345 nm.

[0077] In the absorbance spectrum characteristics, the absorbance peak is a point at which the absorbance at wavelengths of 300 nm or more takes a maximum value, that is, at which the normalized absorbance is 1.0. On the other hand, the absorbance bottom corresponds to a point where the normalized absorbance decreases to a minimum in the absorbance spectrum characteristics. In the case where the absorbance spectrum characteristics have substantially an L shape curve, as in the example shown in FIG. 5, the point at which the normalized absorbance decreases to 10% or less is the absorbance bottom. In the case where the normalized absorbance is 10% or less in a region corresponding to the bottom side of the L shape, the point at which the normalized absorbance is 10% on the shortest wavelength side is set to be the absorbance bottom.

[0078] FIG. 6 shows the case in which the normalized absorbance once decreases to 10% or less at a point A on the shorter wavelength side in the region corresponding to the bottom side of the L shape, then increasing above 10% on the longer wavelength side, and decreasing once again to 10% or less at a point B on the longer wavelength side. In this case, the point B, at which the normalized absorbance decreases to 10% on the longest wavelength side, is set to be the absorbance bottom.

[0079] In short, in the normalized absorbance spectrum characteristics, the normalized absorbance on the longer wavelength side than the absorbance bottom is 10% or less.

[0080] As regards the m-MTDAB that is the material of the hole transport layer HTL, on the shorter wavelength side than the wavelength of 345 nm, the normalized absorbance is more than 10%. On the other hand, on the longer wavelength side than the wavelength of 345 nm, the normalized absorbance is 10% or less. Thus, the absorbance bottom of the m-MTDAB occurs on the shorter wavelength side than the first absorbance peak (about 500 nm) of the first dopant material EM1 and the second absorbance peak (about 400 nm) of the second dopant material EM2.

[0081] In FIG. 5, (a) and (b) indicate the absorbance spectrum characteristics in the state in which no optical quenching occurs in the first dopant material EM1 and second dopant material EM2. In the absorbance spectrum characteristics in the state in which optical quenching occurs in the first dopant material EM1 and second dopant material EM2, the absorbance peaks may slightly become lower than in the state before the optical quenching, or the wavelengths at which the absorbance peaks occur may slightly vary. However, the absorption peaks do not greatly vary, compared to the state before the optical quenching. In particular, the wavelengths at which the absorbance peaks occur do not shift to the shorter wavelength side than the absorbance bottom of the hole transport layer HTL.

[0082] Although not shown, in the case where the absorbance spectrum characteristics have substantially a U shape curve, that part of the U shape curve, which has a lowest normalized absorbance, is set to be the absorbance bottom.

[0083] Next, referring to a flow chart of FIG. 7, a description is given of an example of a manufacturing method of the first to third organic EL elements OLED1 to OLED3.

[0084] To start with, in an array process, a pixel electrode PE is formed on a passivation film.

[0085] Then, in an EL process, a hole transport layer HTL is formed on the pixel electrode PE by a vacuum evaporation method by using a rough mask in which an opening corresponding to the display region is formed. In FIG. 7, this step is indicated by "HTL EVAPORATION".

[0086] Subsequently, a red light emission layer EML1 including a first dopant material EM1 is formed by a vacuum evaporation method by using a rough mask in which an opening corresponding to the display region is formed. In FIG. 7, this step is indicated by "EML1 EVAPORATION".

[0087] Then, regions, which correspond to the pixel PX2 in which the second organic EL element OLED2 is formed and the pixel PX3 in which the third organic EL element OLED3 is formed, are irradiated with light in a range of wavelengths of about 360 to 800 nm with an intensity in a range of 0.001 to 1.0 mW·mm⁻²·nm⁻¹. In this example, the intensity of irradiation light is set at about 0.1 mW·mm⁻²·nm⁻¹. In FIG. 7, this step is indicated by "PHOTO1 EXPOSURE".

[0088] In the exposure step indicated by "PHOTO1 EXPOSURE", in the pixels PX2 and PX3 which are irradiated with light with the wavelengths of about 360 to 800 nm, the first dopant material EM1 in the red light emission layer EML1 absorbs the irradiation light since the first dopant material EM1 has a first absorbance peak in the vicinity of 500 nm. Thereby, optical quenching occurs in the first dopant material EM1 due to decomposition, polymerization or a change in molecular structure. On the other hand, in the pixels PX2 and PX3, the normalized absorbance of the hole transport layer HTL in the wavelength range of irradiation light is relatively low and is 10% or less. Thus, even if the hole transport layer HTL absorbs the irradiation light, there hardly occurs decomposition, polymerization or change in molecular structure.

[0089] Subsequently, a green light emission layer EML2 including a second dopant material EM2 is formed by a vacuum evaporation method by using a rough mask in which an opening corresponding to the display region is formed. In FIG. 7, this step is indicated by "EML2 EVAPORATION".

[0090] Then, the region, which corresponds to the pixel PX3, is irradiated with light in a range of wavelengths of about 360 to 800 nm with an intensity in a range of 0.001 to 1.0 mW·mm⁻²·nm⁻¹. In this example, the intensity of irradiation light is set at about 0.1 mW·mm⁻²·nm⁻¹. In FIG. 7, this step is indicated by "PHOTO2 EXPOSURE". In the meantime, ultraviolet lights with different wavelengths may be radiated in the "PHOTO1 EXPOSURE" and "PHOTO2 EXPOSURE".

[0091] In the exposure step indicated by "PHOTO2 EXPOSURE", in the pixel PX3 which is irradiated with light with the wavelengths of about 360 to 800 nm, the second dopant material EM2 in the green light emission layer EML2 absorbs the irradiation light since the second dopant material EM2 has a second absorbance peak in the vicinity of 400 nm. Thereby, optical quenching occurs in the second dopant material EM2 due to decomposition, polymerization or a change in molecular structure. On the other hand, in the pixel PX3, the normalized absorbance of the hole transport layer HTL in the wavelength range of irradiation light is relatively low and is 10% or less. Thus, even if the hole transport layer HTL absorbs the irradiation light, there hardly occurs decomposition, polymerization or change in molecular structure.

[0092] Subsequently, a blue light emission layer EML3 including a third dopant material EM3 is formed on the green

light emission layer EML2 by a vacuum evaporation method by using a rough mask in which an opening corresponding to the display region is formed. In FIG. 7, this step is indicated by "EML3 EVAPORATION".

[0093] Then, a counter-electrode CE is formed on the blue light emission layer EML3. In FIG. 7, this step is indicated by "CE EVAPORATION".

[0094] Thereafter, a step of sealing by the sealing substrate SUB2 is performed.

[0095] As shown in FIG. 8, in the exposure step indicated by "PHOTO0", light is radiated by using a photomask MASK1 which shields the pixel PX1 from light and has an opening facing the pixels PX2 and PX3. Thereby, in the red light emission layer EML1 that is formed in the preceding step, the first dopant material EM1 of the red light emission layer EML1 that is formed in the pixels PX2 and PX3 absorbs light and transitions into an optical quenching state.

[0096] In the subsequent exposure step indicated by "PHOTO2", light is radiated by using a photomask MASK2 which shields the pixel PX1 and pixel PX2 from light and has an opening facing the pixel PX3. Thereby, in the green light emission layer EML2 that is formed in the preceding step, the second dopant material EM2 of the green light emission layer EML2 that is formed in the pixel PX3 absorbs light and transitions into an optical quenching state.

[0097] As described above, the hole transport layer HTL, red light emission layer EML1, green light emission layer EML2 and blue light emission layer EML3 are the continuous films extending over the first to third organic EL elements OLED1 to OLED3. Similarly, the counter-electrode CE is the continuous film extending over the first to third organic EL elements OLED1 to OLED3. Thus, when these films are formed by the evaporation method, a fine mask in which a fine opening is formed is needless, and the manufacturing cost of the mask can be reduced. In addition, when these films are formed, the amount of material deposited on the mask decreases, and the efficiency of use of the material of the films is enhanced. Moreover, since there is no need to selectively apply the light-emitting materials, a defect of color mixture can be prevented.

[0098] Besides, the second organic EL element OLED2 emits green light since the first dopant material EM1 of the red light emission layer EML1 is in the optical quenching state. The third organic EL element OLED3 emits blue light since the first dopant material EM1 of the red light emission layer EML1 and the second dopant material EM2 of the green light emission layer EML2 are in the optical quenching state. Accordingly, full-color display with high fineness can be realized.

[0099] When optical quenching is caused in the first dopant material EM1 of the red light emission layer EML1 and the second dopant material EM2 of the green light emission layer EML2, the productivity of the organic EL display device can be more improved as the exposure time in the PHOTO0 exposure and PHOTO2 exposure is shorter.

[0100] As means for shortening the exposure time, there is a method of increasing the intensity of exposure. The radiation light wavelength of a high-pressure mercury lamp, which is a light source of a general exposure device, is in the range of 200 to 600 nm, and the peak wavelength, at which the emission light intensity takes a maximum value, is 365 nm in the emission light spectrum characteristics.

[0101] If all wavelengths of the radiation light of the high-pressure mercury lamp are utilized for exposure, the radiation

intensity increases, but the wavelengths include wavelengths of light which is absorbed by not only the first dopant material EM1 and second dopant material EM2, but also the hole transport layer HTL. Consequently, there may possibly occur decomposition, polymerization or a change in molecular structure in the hole transport layer HTL. Consequently, it is possible that the hole transportability of the hole transport layer HTL decreases, and such a problem arises that the performance of the organic EL display device deteriorates.

[0102] It is thinkable to radiate light of wavelengths, which is hardly absorbed by the hole transport layer HTL but is absorbed by only the first host material HM1 and second host material HM2. In such a case, however, an optical element for selecting wavelengths is needed. In addition, at the time of exposure, the radiation intensity decreases due to the limitation of radiation wavelengths, and also the radiation intensity at the time when the radiation light passes through the optical element decreases due to, e.g. absorption of light by the optical element itself. Consequently, since the exposure intensity decreases and the exposure time increases, the productivity may possibly deteriorate.

[0103] Decomposition, polymerization or change in molecular structure is suppressed in the hole transport layer HTL by radiating light that has wavelengths, which are longer than the absorbance bottom in the absorbance spectrum characteristics of the hole transport layer HTL, as the wavelengths of light for use in the exposure steps of "PHOTO0 EXPOSURE" and "PHOTO2 EXPOSURE".

[0104] On the other hand, the first dopant material EM1 and second dopant material EM2, which are to be set in the optical quenching state, have absorption peaks in the absorbance spectrum characteristics on the longer wavelength side than the absorbance bottom of the hole transport layer HTL. Thus, in the exposure steps of "PHOTO1 EXPOSURE" and "PHOTO2 EXPOSURE", light is radiated which has the wavelengths including wavelengths in the vicinity of the absorbance bottom of the hole transport layer HTL, and wavelengths longer than these wavelengths in the vicinity of the absorbance bottom.

[0105] Specifically, as the exposure wavelengths in each exposure step, use can be made of the wavelengths in the range longer than the wavelengths in the ultraviolet range (200 to 400 nm) at which the normalized absorbance of the hole transport layer HTL is 10% or less, and all wavelengths in the visible light range. This wavelength range includes the peak wavelength of the high-pressure mercury lamp that is the light source. Therefore, the exposure intensity can be kept at a high level, and the productivity can be improved by the decrease in exposure time.

[0106] A description is given of examples of variations of elements, which can be adopted in the first to third organic EL elements OLED1 to OLED3 in the present embodiment.

[0107] For example, the organic layer ORG of each of the first to third organic EL elements OLED1 to OLED3 may include a hole injection layer on the pixel electrode side. In this case, the hole injection layer is disposed on the pixel electrode PE, and the hole transport layer HTL is disposed on the hole injection layer. In addition, the organic layer ORG of each of the first to third organic EL elements OLED1 to OLED3 may include an electron injection layer and an electron transport layer on the counter-electrode side. In this case, the electron transport layer is disposed on the blue light emission layer EML3, and the electron injection layer is disposed on the electron transport layer. The hole injection layer, elec-

tron injection layer and electron transport layer, like the hole transport layer HTL, can be formed by a vacuum evaporation method by using a rough mask.

[0108] The pixel electrode PE of each of the first to third organic EL elements OLED1 to OLED3 may have a two-layer structure in which a reflective layer and a transmissive layer are stacked, or may have a single transmissive layer structure or a single reflective layer structure. The reflective layer can be formed of a light-reflective, electrically conductive material such as silver (Ag) or aluminum (Al). The light-transmissive layer can be formed of a light-transmissive, electrically conductive material such as indium tin oxide (ITO) or indium zinc oxide (IZO). In the case where the pixel electrode PE has the two-layer structure comprising the reflective layer and transmissive layer, the reflective layer is disposed on the passivation film PS, and the transmissive layer is disposed on the reflective layer.

[0109] The counter-electrode CE may have a two-layer structure in which a semi-transmissive layer and a transmissive layer are stacked, or may have a single transmissive layer structure or a single semi-transmissive layer structure. The semi-transmissive layer can be formed of an electrically conductive material such as magnesium or silver. The transmissive layer can be formed of a light-transmissive, electrically conductive material such as ITO or IZO.

[0110] The first to third organic EL elements OLED1 to OLED3 may adopt a top-emission-type structure in which emission light is extracted from the counter-electrode side. In this case, the pixel electrode PE of each of the first to third organic EL elements OLED1 to OLED3 includes at least a reflective layer.

[0111] As is shown in FIG. 9, the first to third organic EL elements OLED1 to OLED3 may adopt a micro-cavity structure which comprises a pixel electrode PE having a reflective layer PER, and a counter-electrode CE which is formed of a semi-transmissive layer. In this case, the pixel electrode PE has a two-layer structure including the reflective layer PER, and a transmissive layer PET which is disposed between the reflective layer PER and the hole transport layer HTL. In the first to third organic EL elements OLED1 to OLED3, the organic layer ORG, which is disposed between the transmissive layer PET and the counter-electrode CE, includes, like the example shown in FIG. 3, the hole transport layer HTL, red light emission layer EML1, green light emission layer EML2 and blue light emission layer EML3. According to this structure, a top-emission-type micro-cavity structure is realized. In the case where one of the pixel electrode PE and the counter-electrode CE, which sandwich the organic layer ORG, is composed of a transparent electrode alone, a micro-cavity structure cannot be obtained.

[0112] In the case where the micro-cavity structure is adopted, a light-transmissive thin film, for instance, silicon oxynitride (SiON) or ITO, may be disposed on the counter-electrode CE. Such a thin film is usable as a protection film for protecting the first to third organic EL elements OLED1 to OLED3, and is also usable as an optical matching layer for adjusting the optical path length for optimizing optical interference. Moreover, a light-transmissive insulation film, for instance, silicon nitride (SiN), may be disposed between the reflective layer of the pixel electrode PE and the semi-transmissive layer of the counter-electrode CE. Such an insulation film is usable as an adjusting layer for adjusting an optical interference condition. The optical path length of such an adjusting layer is set at a least common multiple of $\frac{1}{4}$ of the

wavelength of emission light of each of the first to third organic EL elements OLED1 to OLED3. Such an adjusting layer may be disposed only in the first organic EL element OLED1 and the second organic EL element OLED2.

[0113] Of the first to third organic EL elements OLED1 to OLED3, at least the first organic EL element OLED1 and the second organic EL element OLED2 may include an irregular scattering layer which is disposed between the pixel electrode PE and the passivation film PS.

[0114] In the present embodiment, the description has been given of the case in which the hole injectability or hole transportability in the red light emission layer EML1 and green light emission layer EML2 is increased by the ultraviolet irradiation for causing optical quenching in the first dopant material EM1 of the red light emission layer EML1 and the second dopant material EM2 of the green light emission layer EML2. Alternatively, the same advantageous effect can be obtained in the case in which the hole injectability or hole transportability in the red light emission layer EML1 and green light emission layer EML2 is decreased by the ultraviolet irradiation.

[0115] A description is given of examples of variations which can be adopted in the manufacturing method of the first to third organic EL elements OLED1 to OLED3.

[0116] The exposure step that is indicated by "PHOTO1 EXPOSURE" may be performed at any timing, if the timing is after the step of forming the red light emission layer EML1, which is indicated by "EML1 EVAPORATION". For example, the exposure step indicated by "PHOTO1 EXPOSURE" may be performed after the step of forming the green light emission layer EML2 which is indicated by "EML2 EVAPORATION", or after the step of forming the blue light emission layer EML3 which is indicated by "EML3 EVAPORATION", or after the step of forming the counter-electrode CE which is indicated by "CE EVAPORATION".

[0117] The exposure step that is indicated by "PHOTO2 EXPOSURE" may be performed at any timing, if the timing is after the step of forming the green light emission layer EML2, which is indicated by "EML2 EVAPORATION". For example, the exposure step indicated by "PHOTO2 EXPOSURE" may be performed after the step of forming the blue light emission layer EML3 which is indicated by "EML3 EVAPORATION", or after the step of forming the counter-electrode CE which is indicated by "CE EVAPORATION".

[0118] In the case of the structure in which the organic layer ORG of each of the first to third organic EL elements OLED1 to OLED3 includes the electron transport layer, a step of forming the electron transport layer may be added after the step of forming the blue light emission layer EML3 which is indicated by "EML3 EVAPORATION".

[0119] In the present embodiment, the description has been given of the case in which two exposure steps indicated by "PHOTO0 EXPOSURE" and "PHOTO2 EXPOSURE" are performed. Alternatively, by making use of a halftone mask, optical quenching may be caused in the first dopant material EM1 and second dopant material EM2 by a single exposure step. This halftone exposure step may be performed at any timing, if the timing is after the step of forming the green light emission layer EML2. The halftone mask, which is used in this case, has different transmittances corresponding to the respective regions where the first to third organic EL elements OLED1 to OLED3 are to be formed.

[0120] Specifically, the transmittance corresponding to the region where the third organic EL element OLED3 is to be

formed is higher than the transmittance corresponding to the region where the second organic EL element OLED2 is to be formed. The transmittance corresponding to the region where the second organic EL element OLED2 is to be formed is higher than the transmittance corresponding to the region where the first organic EL element OLED1 is to be formed. Thereby, the exposure step is simplified, and the productivity is improved.

[0121] In the exposure steps indicated by “PHOTO0 EXPOSURE” and “PHOTO2 EXPOSURE”, it is preferable that the oxygen concentration in the exposure device be set at 20 ppm. Under this condition of the oxygen concentration, the optical quenching in the first dopant material EM1 and second dopant material EM2 is promoted.

[0122] For example, FL-2CBP is used as the host material, tri(2-phenylpyridine)iridium (III) (abbreviation: Ir(ppy)3) is used as the dopant material, and a thin film with a thickness of 30 nm and a dopant concentration of 8% is formed on a glass substrate by a vacuum evaporation method. Light of 355 nm or more was radiated for 10 minutes on this formed thin film by using a mercury xenon lamp light source, both in the environment in which the oxygen concentration is 1 ppm or less and the environment in which the oxygen concentration is 20 ppm.

[0123] Before and after the light radiation, the photoluminescence intensity (PL intensity) was compared by a photoluminescence method. In the case where the PL intensity before the light radiation is assumed to be 100%, the PL intensity decreased to 49% after the light radiation in the environment in which the oxygen concentration is 1 ppm, and the PL intensity decreased to 38% after the light radiation in the environment in which the oxygen concentration is 20 ppm.

[0124] It can be assumed that the decrease in PL intensity by the light radiation occurs due to the optical quenching of the dopant material. Therefore, in the exposure steps indicated by “PHOTO1 EXPOSURE” and “PHOTO2 EXPOSURE”, by performing the exposure in the environment in which the oxygen concentration is 20 ppm or more, the optical quenching of the dopant material can be caused in a shorter time, and the productivity can be enhanced.

[0125] The present invention is not limited directly to the above-described embodiments. In practice, the structural elements can be modified and embodied without departing from the spirit of the invention. Various inventions can be made by properly combining the structural elements disclosed in the embodiments. For example, some structural elements may be omitted from all the structural elements disclosed in the embodiments. Furthermore, structural elements in different embodiments may properly be combined.

[0126] In the above-described embodiment, the organic EL display device includes three kinds of organic EL elements with different emission light colors, namely, the first to third organic EL elements OLED1 to OLED3. Alternatively, the organic EL display device may include, as organic EL elements, only two kinds of organic EL elements with different emission light colors, or four or more kinds of organic EL elements with different emission light colors.

[0127] In the present embodiment, the description has been given of the case in which when the dopant material is in an optical quenching state, no light is emitted at all from the dopant material. However, if the same advantageous effect can be obtained, the invention is applicable to the case in

which when the dopant material is in an optical quenching state, light is hardly emitted from the dopant material.

What is claimed is:

1. An organic EL display device comprising:
 - an insulative substrate;
 - a pixel electrode which is disposed above the substrate and is disposed in each of first to third organic EL elements having different emission light colors;
 - a first light emission layer which includes a first dopant material having a first absorbance peak in absorbance spectrum characteristics of the first dopant material, the first light emission layer extending over the first to third organic EL elements and being disposed above the pixel electrode;
 - a second light emission layer which includes a second dopant material having a second absorbance peak in absorbance spectrum characteristics of the second dopant material, the second light emission layer extending over the first to third organic EL elements and being disposed above the first light emission layer;
 - a third light emission layer which includes a third dopant material, the third light emission layer extending over the first to third organic EL elements and being disposed above the second light emission layer;
 - a counter-electrode which extends over the first to third organic EL elements and is disposed above the third light emission layer; and
 - a hole transport layer which is formed of a material having an absorbance bottom on a shorter wavelength side than the first absorbance peak of the first dopant material and the second absorbance peak of the second dopant material in absorbance spectrum characteristics of the hole transport layer, the hole transport layer extending over the first to third organic EL elements and being disposed between the pixel electrode and the first light emission layer.
2. The organic EL display device according to claim 1, wherein the first dopant material of the second organic EL element is in an optical quenching state, and the first dopant material and the second dopant material of the third organic EL element are in an optical quenching state.
3. The organic EL display device according to claim 1, wherein the hole transport layer has a normalized absorbance of 10% or less at wavelengths of 350 nm or more in normalized absorbance spectrum characteristics thereof.
4. The organic EL display device according to claim 1, wherein each of the first absorbance peak and the second absorbance peak is a point with a maximum absorbance value at wavelengths of 300 nm or more.
5. The organic EL display device according to claim 1, wherein the absorbance bottom is a point at which a normalized absorbance is 10% or less on a longest wavelength side in the normalized absorbance spectrum characteristics.
6. The organic EL display device according to claim 1, wherein at least one of the first dopant material, the second dopant material and the third dopant material is a phosphorescent material.
7. The organic EL display device according to claim 1, wherein the first dopant material has a central light emission wavelength in a first wavelength range, the second dopant material has a central light emission wavelength in a second wavelength range including shorter wavelengths than the first wavelength range, and the third dopant material has a central

light emission wavelength in a third wavelength range including shorter wavelengths than the second wavelength range.

8. The organic EL display device according to claim 1, wherein the pixel electrode includes a reflective layer and a transmissive layer which is disposed between the reflective layer and the hole transport layer.

9. The organic EL display device according to claim 1, wherein the counter-electrode includes a semi-transmissive layer.

10. The organic EL display device according to claim 1, further comprising a sealing substrate which seals the first to third organic EL elements.

11. The organic EL display device according to claim 1, further comprising a driver for driving the first to third organic EL elements, the driver being disposed above the substrate.

12. An organic EL display device comprising:

- an insulative substrate;
- a pixel electrode which is disposed above the substrate and is disposed in each of first to third organic EL elements having different emission light colors;
- a first light emission layer which includes a first dopant material having a first absorbance peak in absorbance spectrum characteristics of the first dopant material, the first light emission layer extending over the first to third organic EL elements and being disposed above the pixel electrode;
- a second light emission layer which includes a second dopant material having a second absorbance peak in absorbance spectrum characteristics of the second dopant material, the second light emission layer extending over the first to third organic EL elements and being disposed above the first light emission layer;
- a third light emission layer which includes a third dopant material, the third light emission layer extending over the first to third organic EL elements and being disposed above the second light emission layer;
- a counter-electrode which extends over the first to third organic EL elements and is disposed above the third light emission layer; and
- a hole transport layer which has an absorbance bottom, at which a normalized absorbance is 10% or less, on a shorter wavelength side than the first absorbance peak of the first dopant material and the second absorbance peak

of the second dopant material in normalized absorbance spectrum characteristics of the hole transport layer, the hole transport layer extending over the first to third organic EL elements and being disposed between the pixel electrode and the first light emission layer.

13. The organic EL display device according to claim 12, wherein the first dopant material of the second organic EL element is in an optical quenching state, and

the first dopant material and the second dopant material of the third organic EL element are in an optical quenching state.

14. The organic EL display device according to claim 12, wherein each of the first absorbance peak and the second absorbance peak is a point with a maximum absorbance value at wavelengths of 300 nm or more.

15. The organic EL display device according to claim 12, wherein the absorbance bottom is a point at which the normalized absorbance is 10% or less on a longest wavelength side in the normalized absorbance spectrum characteristics.

16. The organic EL display device according to claim 12, wherein at least one of the first dopant material, the second dopant material and the third dopant material is a phosphorescent material.

17. The organic EL display device according to claim 12, wherein the first dopant material has a central light emission wavelength in a first wavelength range, the second dopant material has a central light emission wavelength in a second wavelength range including shorter wavelengths than the first wavelength range, and the third dopant material has a central light emission wavelength in a third wavelength range including shorter wavelengths than the second wavelength range.

18. The organic EL display device according to claim 12, wherein the pixel electrode includes a reflective layer and a transmissive layer which is disposed between the reflective layer and the hole transport layer.

19. The organic EL display device according to claim 12, wherein the counter-electrode includes a semi-transmissive layer.

20. The organic EL display device according to claim 12, further comprising a sealing substrate which seals the first to third organic EL elements.

* * * * *

专利名称(译)	有机EL显示设备		
公开(公告)号	US20100078629A1	公开(公告)日	2010-04-01
申请号	US12/535977	申请日	2009-08-05
[标]申请(专利权)人(译)	东芝移动显示器有限公司		
申请(专利权)人(译)	东芝移动显示CO., LTD.		
当前申请(专利权)人(译)	日本展示CENTRAL INC.		
[标]发明人	YOKOYAMA SHUHEI OOTA MASUYUKI		
发明人	YOKOYAMA, SHUHEI OOTA, MASUYUKI		
IPC分类号	H01L51/52		
CPC分类号	H01L2251/552 H01L51/5036		
优先权	2008248482 2008-09-26 JP		
其他公开文献	US8110826		
外部链接	Espacenet USPTO		

摘要(译)

一种有机EL显示装置，包括：像素电极，设置在第一至第三有机EL元件的每一个中；第一发光层，包括具有第一吸收峰的第一掺杂剂材料，第一发光层在第一至第三吸收峰上延伸有机EL元件设置在像素电极上方，第二发光层包括具有第二吸收峰的第二掺杂材料并设置在第一发光层上方，第三发光层设置在第二发光层上方，设置在第三发光层上方的反电极，和由在第一吸收峰的短波长侧具有吸收底部的材料和在吸收光谱特性中的第二吸收峰形成的空穴传输层空穴传输层。

